



Model Number

ENA36IL-S***-Analog

Features

- Very small housing
- High climatic resistance
- 4 Bit multiturn
- Models with analog voltage or current output
- Surge and reverse polarity protection

Description

This absolute encoder with internal magnetic sampling is available with an analog voltage output or an analog current output. Depending on the model, the analog output provides a voltage value or a current value corresponding to the shaft setting. The encoder can be easily programmed by means of electrical inputs and push buttons.

Technical data

General specifications

Detection type	magnetic sampling
Device type	Absolute encoders
Measurement range	min. 0 ... 22.5 ° max. 16 x 360 °
Resolution	17 Bit (13 bits/revolution)

Electrical specifications

Operating voltage U_B	8 ... 32 V DC
Current consumption	typ. 15 mA (with voltage output) typ. 20 mA (with current output)

Input 1

Input type	lower limit of measurement range
Signal voltage	
High	8 ... 32 V DC
Signal duration	≥ 1 s

Input 2

Input type	upper limit of measurement range
Signal voltage	
High	8 ... 32 V DC
Signal duration	≥ 1 s

Analog output

Output type	analog voltage output or analog current output (see type code)
Default setting	rising ramp at ccw rotation
Linearity error	≤ 0.15 %
Load resistor	min. 5000 Ω (with voltage output) , min. 500 Ω (with current output) ; Max. value for supply voltage 8 V. For higher supply voltage lower load resistance can be used.

Connection

Connector	M12 connector, 5 pin
Cable	Ø6 mm, 4 x 2 x 0.14 mm ² , 1 m

Standard conformity

Degree of protection	acc. DIN EN 60529
Connection side	cable models: IP54 connector models: IP65
Shaft side	IP65
Climatic testing	DIN EN 60068-2-3, no moisture condensation
Emitted interference	EN 61000-6-4:2007
Noise immunity	EN 61000-6-2:2005
Shock resistance	DIN EN 60068-2-27, 100 g, 6 ms
Vibration resistance	DIN EN 60068-2-6, 10 g, 10 ... 1000 Hz

Ambient conditions

Operating temperature	cable, flexing: -5 ... 70 °C (-23 ... 158 °F), cable, fixed: -30 ... 70 °C (-22 ... 158 °F) connector models: -40 ... 85 °C (-40 ... 185 °F)
Storage temperature	cable models: -30 ... 70 °C (-22 ... 158 °F) connector models: -30 ... 85 °C (-22 ... 185 °F)
Relative humidity	98 % , no moisture condensation

Mechanical specifications

Material	
Housing	nickel-plated steel
Flange	Aluminum
Shaft	Stainless steel
Mass	approx. 150 g , with cable
Rotational speed	max. 12000 min ⁻¹
Moment of inertia	30 gcm ²
Starting torque	< 3 Ncm
Shaft load	
Axial	20 N
Radial	40 N

Dimensions

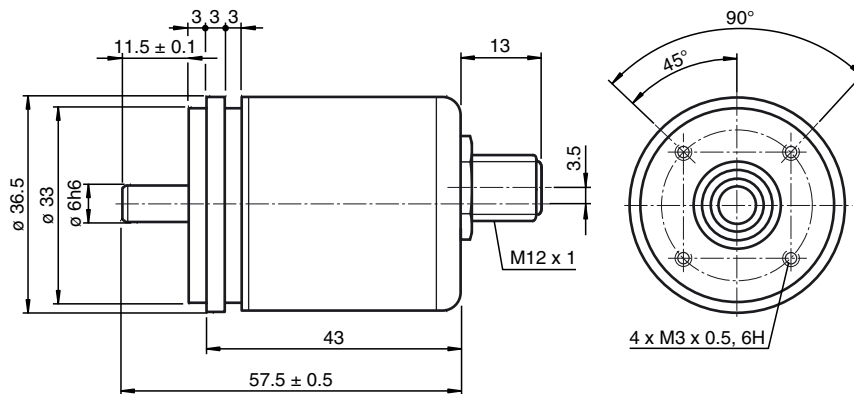
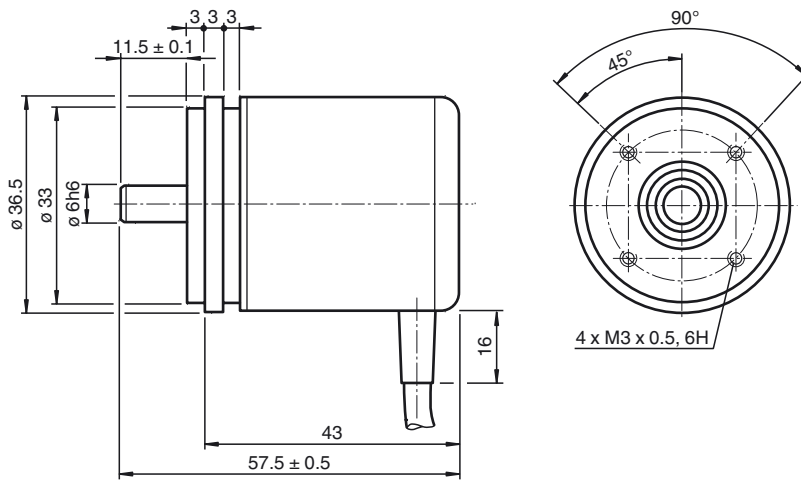
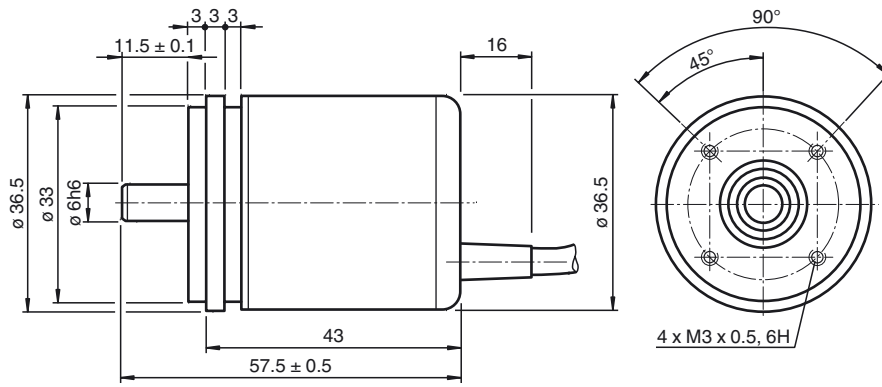

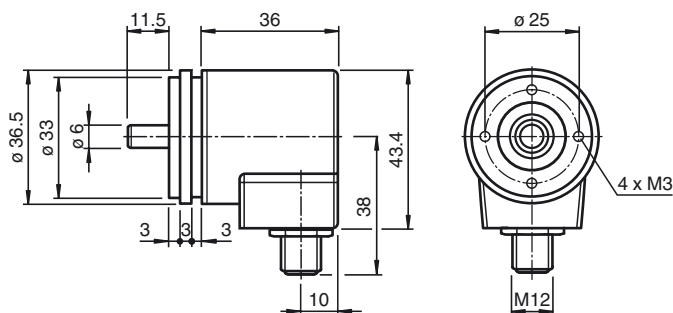

Electrical connection

Signal	Wire end	M12 connector
Analog output	Green	1
+V _S (encoder)	Red	2
GND (encoder)	Yellow	3
Set 2	White	4
Set 1	Brown	5
Shielding	Screen	Housing
Pinout	-	

Description of rotary encoder functions

Default Settings

	Lower measuring range limit	Mid measuring range	Upper measuring range limit
Singleturn absolute rotary encoder	0	180°	360°
Multiturn absolute rotary encoder	0	8 x 360°	16 x 360°

Programming Encoders with No Operating Buttons

Scaling the measuring range

Use signal inputs "Set 1" and "Set 2" to scale the measuring range (minimum measuring range: 22.5°).

1. Connect signal inputs "Set 1" and "Set 2" simultaneously to +U_B for 15 seconds. The programming mode is activated now.
2. Turn the rotary encoder shaft to position 1 (lower measuring range limit).
3. Connect signal input "Set 1" to a high-potential source ($+U_{B \min} \leq \text{high potential} \leq +U_{B \max}$) for 1 second.
4. Connect signal input "Set 1" to ground
5. Turn the rotary encoder shaft to position 2 (upper measuring range limit).
6. Connect signal input "Set 2" to a high-potential source ($+U_{B \min} \leq \text{high potential} \leq +U_{B \max}$) for 1 second.
7. Connect signal input "Set 2" to ground

The analog output is now scaled to the programmed measuring range and the rotary encoder will operate in normal mode.

Resetting to the Default Setting

1. Connect the two signal inputs ("Set 1" and "Set 2") to a high-potential source ($+U_{B \min} \leq \text{high potential} \leq +U_{B \max}$) for 1 second.

The measuring range is then reset to the default setting.

Programming Encoders with Operating Buttons

Scaling the measuring range

Use operating buttons "Lim1" and "Lim2" to scale the measuring range (minimum measuring range: 22.5°).

1. Press the two operating buttons ("Lim1" and "Lim2") simultaneously. Both LEDs will light up. Press and hold the operating buttons for 15 seconds until the two LEDs start to flash. The rotary encoder is now in programming mode.
2. Turn the rotary encoder shaft to position 1 (lower measuring range limit).
3. Press and hold operating button "Lim1" for 1 second. The green LED will now light up permanently.
4. Turn the rotary encoder shaft to position 2 (upper measuring range limit).
5. Press and hold operating button "Lim2" for 1 second.

The analog output is now scaled to the programmed measuring range and the rotary encoder will operate in normal mode. Only the green LED will light up.

Resetting to the Default Setting

1. Press the two operating buttons ("Lim1" and "Lim2") simultaneously. Both LEDs will light up. Press and hold the operating buttons for 30 seconds. After 15 seconds, the two LEDs will start to flash.

When the green LED goes out and the yellow LED lights up permanently, the measuring range is reset to the default setting.

Status LEDs

The rotary encoder is equipped with two status LEDs. These LEDs have three possible states: off, flashing, or on. The LEDs use different combinations of these states to indicate the status of the rotary encoder.

Yellow LED	Green LED	Description
On	Off	Rotary encoder operation using default settings
Off	On	Rotary encoder operation using scaled measuring range (customer-specific setting)
On	On	Programming mode initiated (temporary state)
Flashes	Flashes	Rotary encoder in programming mode
On	Flashes	Position 2 set, waiting for position 1
Flashes	On	Position 1 set, waiting for position 2

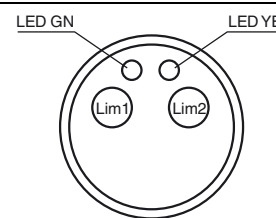

Analog Output Properties

Depending on its design, the rotary encoder projects the current angular position of the rotary encoder shaft in an analog current or voltage value. The following graphic shows the values the output accepts at the various angular positions:

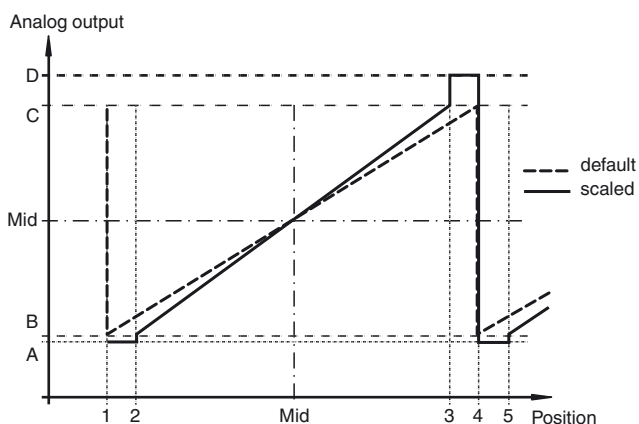

Legend:

Encoder type ¹⁾		Angular position					
		1	2	Mid	3	4	5
Singleturn	Factory default setting	0°	-	180°	-	360°	-
	Scaled	0°	Lower measuring range limit	-	Upper measuring range limit	360°	Lower measuring range limit
Multiturn	Factory default setting	0°	-	2 ⁿ x 180°	-	2 ⁿ x 360°	-
	Scaled ²⁾	0°	Lower measuring range limit	-	Upper measuring range limit	2 ⁿ x 360°	Lower measuring range limit

n = whole number from 1 to 16

1) See model number

2) Overflow at 360°, 720°, 1440°, 2880°, 5760°, etc. depending on the scale set.

Encoder output type	Analog output value				
	A	B	Mid	C	D
0 V ... 5 V	-	0 V	2.5 V	5 V	-
0.5 V ... 4.5 V	0.25 V	0.5 V	2.5 V	4.5 V	4.75 V
0 V ... 10 V	-	0 V	5 V	10 V	-
0.5 V ... 9.5 V	0.25 V	0.5 V	5 V	9.5 V	9.75 V
4 mA ... 20 mA	3.6 mA	4 mA	12 mA	20 mA	22 mA
0 mA ... 20 mA	-	0 mA	10 mA	20 mA	-

Release date: 2017-05-16 09:40 Date of issue: 2017-05-16 t186711_eng.xml

Model number

E N A 3 6 I L - S 0 6 S A - - - 1 3 - - -

Connection type

- C1** Cable, 1 m
- C2** Cable, 2 m
- C5** Cable, 5 m
- CA** Cable, 10 m
- BD** M12 device plug, 5-pin

Connection alignment

- A** axial
- R** radial

Interface, electric

- U01** 0 ... 10 V
- U04** 0.5 ... 4.5 V
- U05** 0 ... 5 V
- U09** 0.5 ... 9.5 V
- UP1** 0 ... 10 V with push buttons
- UP4** 0.5 ... 4.5 V with push buttons
- UP5** 0 ... 5 V with push buttons
- UP9** 0.5 ... 9.5 V with push buttons
- I02** 0 ... 20 mA
- I42** 4 ... 20 mA
- IP0** 0 ... 20 mA with push buttons
- IP4** 4 ... 20 mA with push buttons

Singleturn resolution

13 13 bit

Multiturn resolution

- 00** Singleturn rotary encoder
- 04** Multiturn rotary encoder, 4 bit

Degree of protection

- 4** IP54
- 5** IP65

Flange

SA Servo flange

Shaft diameter

06 6 mm

Shaft type

S Solid shaft

Version

IL Industrial Line

Size

36 Housing diameter: 36 mm

Device type

ENA Absolute rotary encoder

Release date: 2017-05-16 09:40 Date of issue: 2017-05-16 t186711_eng.xml